



Features:

- 2.8m² (30ft²) of plant growth area total on two tiers
- 635mm (25") of growth height on each of the two tiers
- 750 μ mol m⁻² s⁻¹ PPFD of lighting
- Ideal for Arabidopsis and other plants requiring shorter growth heights
- Two tiers of shelving maximizes growth area
- Channel floor system for uniform airflow
- Easy access to mechanical/electrical system for ease of service



Quality product.
Excellent service.
Innovative designs.

 **BioChambers**
PROVIDING GROWTH TO RESEARCH.

SHORT PLANT SERIES

SPC-28

INTRODUCTION

BioChambers' plant growth chamber model SPC-28 was specifically designed to maximize the plant growth area by incorporating a multi-tier shelf design. The chamber features two fixed height light tiers of shelving and an open channel floor delivering upward airflow ensuring each tier of shelving is under the same environmental conditions. The electrical and cooling systems are located at waist height with ease of service in mind. BioChambers' plant growth chambers provide tight uniform control of temperature, a balanced lighting spectrum using a combination of broad spectrum and far-red LED modules, and adjustable airflow.

1.0 CONTROLLER

- 1.1 **Controller Version:** BioChambers NEXUS.
- 1.2 **Interface:** Fanless panel PC with a 305mm (12") color touch screen.
- 1.3 **Ethernet Connection:** Secure remote access using a unique site specific webkey allowing the chambers/rooms to be connected to a facility supplied local area network (LAN)/internet.
- 1.4 **Security:** Multiple levels of password security for researchers, administrators, service technicians, and BioChambers' factory technicians.
- 1.5 **NEXUS Viewer:** Instantly view the status of all your experiments. Single or multiple chambers/rooms can be remotely monitored and operated from a central location via the LAN/internet. NEXUS Viewer can be installed on up to three existing computer stations.
- 1.6 **Schedule:** Multi-line schedule can be created for temperature, lighting (day length), light intensity, and fan speed using the touch screen interface or remotely using the facility provided LAN/internet. Available options: humidity, carbon dioxide, auxiliary circuits primarily for automatic watering, etc... can also be scheduled.
- 1.7 **Multi-Day:** Multi-day changing environmental conditions can be scheduled.
- 1.8 **Ramping:** Temperature and light intensity changes gradually (ramping) from setpoint to setpoint. Available options: humidity and carbon dioxide can also be ramped.
- 1.9 **Astronomical Clock:** Researchers can produce photoperiod schedules for locations worldwide by simply entering the latitude and longitude.
- 1.10 **Graphing:** Controlled parameters such as temperature, light intensity, and the following available options: humidity and carbon dioxide can be graphed to show setpoint versus actual conditions.
- 1.11 **Research Data:** Controller equipped with a memory card to store multiple schedules and logged data such as temperature, alarms, etc... Log rate and duration can be set by the user.
- 1.12 **Data Export:** Data can be exported to the researcher's/administrator's computer for further analysis.
- 1.13 **Start-up:** Provisions for chamber/room start-up delay in facilities with multiple chambers/rooms helping to reduce the initial inrush current after a power outage.
- 1.14 **Alarms:** Notification via e-mails, building alarm contacts connected to a facility supplied building security system, and on chamber/room audible alarm with red indicator light.
- 1.15 **Service Data:** Refrigeration system pressures and temperatures along with other service parameters are logged. Log rate and duration can be set independently of the research log.
- 1.16 **Service Screen:** Displays compressor discharge and suction pressures and temperatures, facility water supply and return temperatures, automatic temperature setting safety limits status, lamp hours, sensor calibration hours, temperature control valve position, and more.
- 1.17 **Service:** On-screen override switches with a 10 minute schedule bypass are provided for the service technician to place the chamber/room into full cooling or heating and all lights on or off. This enables faster and easier service work as the technician does not need to learn how to program a schedule.



SHORT PLANT SERIES

SPC-28

2.0 CONSTRUCTION

- 2.1 Exterior Dimensions:** 2690mmW x 890mmD x 2005mmH (106"W x 35"D x 79"H). Add 865mm (34") to the width to service the chamber (custom heights are available).
- 2.2 Assembly:** Chamber shipped assembled as one unit for easy installation in the facility.
- 2.3 Interior Dimensions:** 1840mmW x 815mmD (72½"W x 32"D).
- 2.4 Growth Area:** 2.81m² (30.2ft²) total on two tiers.
- 2.5 Growth Height:** 635mm (25") each of the two tiers.
- 2.6 Growth Capacity:** 1.8m³ (63ft³) total on two tiers.
- 2.7 Interior:** Pre-painted white smooth aluminum.
- 2.8 Exterior:** 22ga. Stainless Steel Type 304 #4 Brushed.
- 2.9 Lamp Canopies:** Two fixed height, non-barriered lamp canopies.
- 2.10 Drain Pan/Floor:** Constructed of anodized aluminum on each shelf and floor drain pan constructed of stainless steel for superior corrosion resistance.
- 2.11 Insulation:** 38mm (1½") CFC free, high-density expanded polystyrene.
- 2.12 Electronics:** Filtered air blown into the control panel, providing cooling to the electronics and positive pressure in the control panel keeping dust out, extending the life of the electronics.
- 2.13 Service:** Easy access to electronics and mechanical components located on the side of the chamber.
- 2.14 Instrument Ports:** Two 50mm (2") with light tight covers.
- 2.15 Reach-In Doors:** Two 650mmW x 1460mmH (25½"W x 57½"H) with light tight magnetic gaskets and self closing cam-lift hinges.
- 2.16 Observation Window:** One 380mm x 280mm (15" x 11") dual pane glass window with light tight cover.
- 2.17 Control Panel:** Display mounted on the left side of the chamber when facing the doors (right side available upon advanced request).
- 2.18 Aisle/Vestibule:** Not applicable.

**3.0 AIR TEMPERATURE**

- 3.1 Ambient:** Designed for a maximum ambient of 35°C outside the chamber.
- 3.2 Range:** 4°C to 40°C all lights off, 10°C to 35°C all lights on (extended temperature options are available).
- 3.3 Control:** PID control, +/-0.5°C at the aspirated sensor.
- 3.4 Temperature Limits:** Automatically set when the user selects a schedule. One high/low and one lamp safety temperature limit sensor independent of the main temperature sensor.
- 3.5 Sensor Box:** Moveable, aspirated, and sensors are shielded from the radiative heat produced by the lights.
- 3.6 Temperature Sensor:** High precision fast responding thermistor sensor.

4.0 LIGHTING

- 4.1 Type:** LED Fluence modules with two dimmable channels (other lighting options are available).
- 4.2 Intensity:** 750µmol m⁻² s⁻¹ PPF (Photosynthetic Photon Flux Density measured in the PAR (Photosynthetically Active Radiation) range of 400-700nm) on each tier of shelving. Light intensity is measured at 150mm (6") from the lamp canopy at 25°C and averaged on a 150mm (6") grid.
- 4.3 Light Source:** Combination of Fluence LED modules with PhysioSpec Indoor (R4) broad spectrum and LED modules with PfrSpec far-red spectrum.
- 4.4 Programming:** Via NEXUS controller.
- 4.5 Light Intensity Control:** Two channel dimmable system per tier, total of 4 dimmable channels. PhysioSpec Indoor (R4) broad spectrum LED modules are on one dimming channel and PfrSpec far-red spectrum LED modules are on the second dimming channel. For each channel, users program a percentage setpoint within the dimmable range from 10% to 100% via the controller.
- 4.6 Lamp Heat:** Cooling system sized to remove all heat generated by the lights.
- 4.7 Light Sensor:** One quantum sensor measures PPF and data is logged by the controller.

SHORT PLANT SERIES

SPC-28**5.0 COOLING SYSTEM**

- 5.1 Type:** Direct expansion cooling system with a water-cooled condenser (other options are available).
- 5.2 Temperature Valve:** No maintenance electronic proportional hot gas bypass system for close temperature control and continuous compressor operation.
- 5.3 Compressor:** Scroll compressor.
- 5.4 Coolant:** HFO based R-449a or R-448a.
- 5.5 Cooling Coil:** Copper tube and aluminum fin construction.
- 5.6 Analysis:** Compressor discharge pressure, suction pressure, and temperatures are logged for ease of service. Facility water supply and return temperatures are also logged.
- 5.7 Safety:** One suction pressure switch and one discharge pressure switch is provided for the refrigeration system to prevent short cycling and compressor burn out.
- 5.8 Barrired Lamplift:** Not applicable.
- 5.9 Defrost Cycle:** Not applicable.

6.0 AIR DISTRIBUTION

- 6.1 Air Flow:** Vertical uniformly upward through an anodized aluminum open channel floor.
- 6.2 Fan Type:** Energy efficient electronically commutated (EC) motor with built in fan speed control and tach output.
- 6.3 Fan Speed:** Can be programmed from 50% to 100% in the controller, enabling researchers to vary the airflow through the plants (85% or higher recommended, temperature gradients increase at lower fan speeds).
- 6.4 Fresh Air:** Filtered fresh air with a manually adjustable vent: 1.4m³/min (50ft³/min).

7.0 RESEARCH SAVER

- 7.1 Surge Protector:** Over voltage protection of the controller and control circuit from electrical surges.
- 7.2 Capacitor Back-up:** Provides time for soft shutdown of the controller.
- 7.3 Power Phase Detector:** Loss of power phase alarm protects the compressor and other components.
- 7.4 Air Flow:** Tach output of each fan displayed in the controller with automatic low rpm alarm to detect fan failure.
- 7.5 Factory Diagnostics:** Through a facility supplied LAN/internet connection a BioChambers' factory technician can remotely access the chamber/room to analyze the mechanical, electrical, and control systems.
- 7.6 Testing:** 100% assembled, tested, and run-in at the factory before being disassembled for shipment to the site reducing on-site assembly time and disruptions.
- 7.7 Quality Standard:** ISO 9001:2015 certified company.

8.0 WARRANTY

- 8.1 Duration:** Two years parts and labor.
- 8.2 Diagnostics:** Additional years three to five remote diagnostics service.

9.0 ELECTRICAL

- 9.1 Service:** 120/208V/3-phase/60Hz/4 Wire + ground (50Hz option: 240/415V/3-phase/50Hz/4 Wire + ground). Electrical service to be provided by others (contact BioChambers for utility requirements).
- 9.2 Electrical Safety:** Chamber/Room is CSA inspected (CE where applicable).

10.0 INSTALLATION & CUSTOMER TRAINING

- 10.1 Manuals:** Controller manual, operation & maintenance manual, and electrical schematics provided.
- 10.2 Training:** Please consult with BioChambers for training options.
- 10.3 Installation:** Please consult with BioChambers for installation options.

SHORT PLANT SERIES

SPC-28

Available Options

BioChambers Rooms and Chambers are available with a variety of options and accessories. If your research has specific requirements, BioChambers can outfit your equipment to meet your needs. These are just a few of the standard options we have available. Ask for more information.



T5 FLUORESCENT LIGHTING

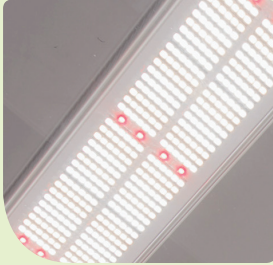

HIGH PPFD LED LIGHTING

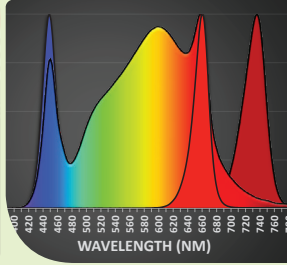

ADJUSTABLE SPECTRUM LED LIGHTING

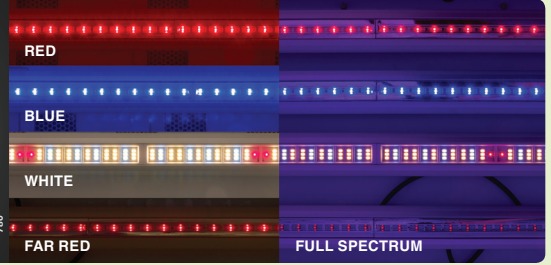

ADDITIVE HUMIDITY SPRAY NOZZLES



RELATIVE HUMIDITY DATA LOGGING



DEHUMIDIFICATION BY DESSICANT

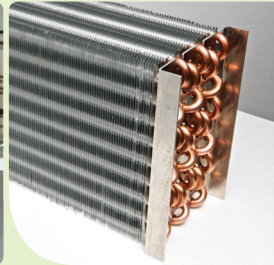

DEHUMIDIFICATION BY REFRIGERATION



PPFD DATA LOGGING



CUSTOM GROWTH HEIGHT

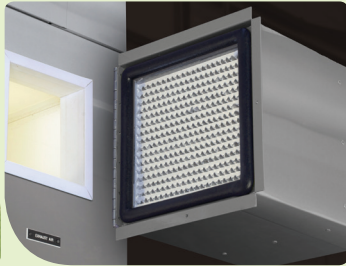

CONTAINMENT HEPA FILTRATION



LEFT OR RIGHT HAND CONTROL PANEL



PROGRAMMABLE RECEPTACLE



EXTENDED WARRANTY



REMOTE AIR COOLED CONDENSER (AC or EC MOTOR)

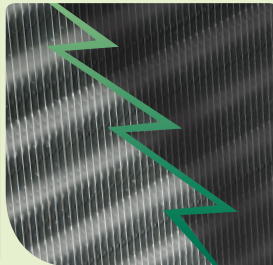

EVAPORATOR COATING



ADDITIVE CO₂



CO₂ SCRUBBER



LOW TEMPERATURE DEFROST



EXTENDED TEMPERATURE RANGE



DRIP IRRIGATION



PROGRAMMED OUTPUT IRRIGATION

SHORT PLANT SERIES
SPC-28

Metric (mm) [Imperial (")]

- - Ethernet connection
- ⊗ - Purified water connection (if humidity option selected)
- - Electrical connection
- - Ø 3/4" Drain location
- ⊠ - Cooling water or refrigeration line connections for condenser
- △ - Electrical line connections for air-cooled condenser (if option selected)

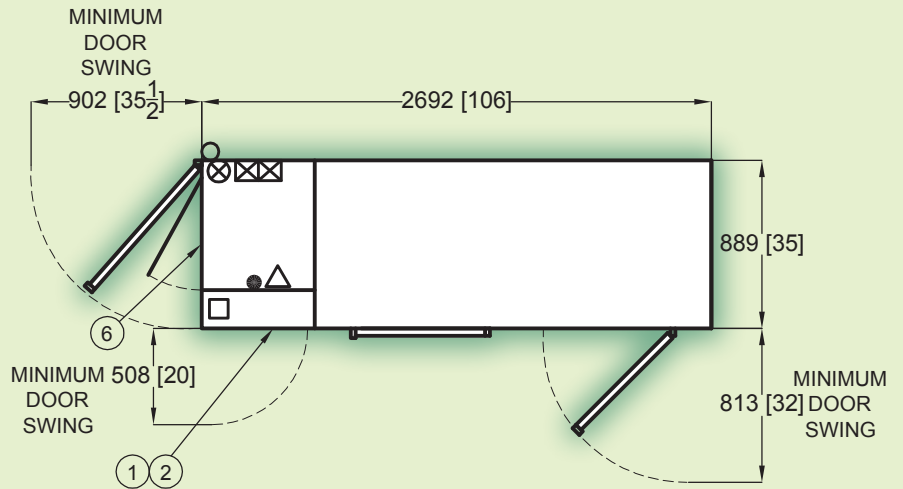

BIOCHAMBERS CAN MANUFACTURE THIS PRODUCT AT CUSTOM HEIGHTS.

BIOCHAMBERS CAN MANUFACTURE THIS PRODUCT WITH THE CONTROL PANEL MOUNTED ON THE RIGHT SIDE UPON ADVANCED REQUEST.

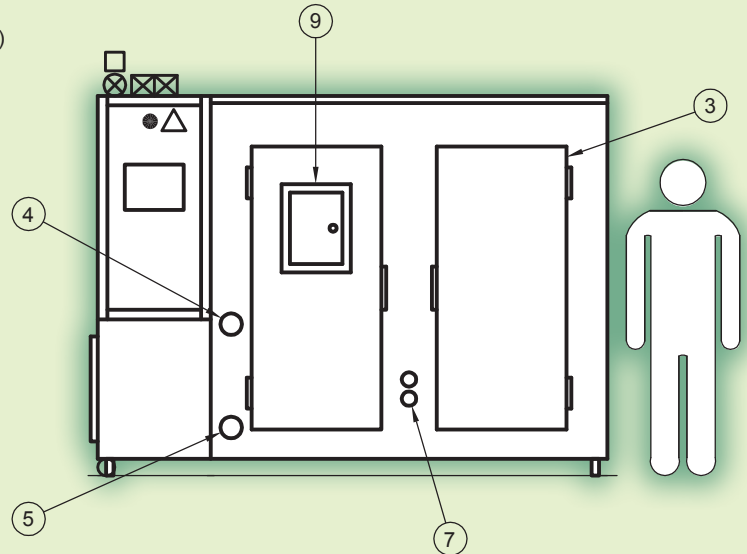
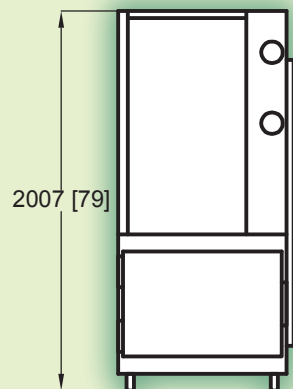

1. Control Panel
2. Touch Screen Interface
3. Door Opening 648 [25-1/2] x 1461 [57-1/2]
4. Fresh Air
5. Exhaust Air
6. Cooling System
7. Instrument Ports
8. Lighting Drivers
9. Viewing Window
10. Fixed Lamp Canopy
11. N/A
12. Air Plenum

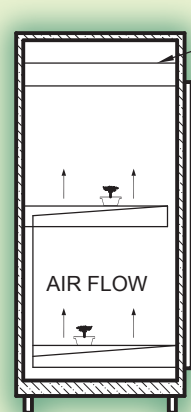

SECTIONED SIDE VIEW

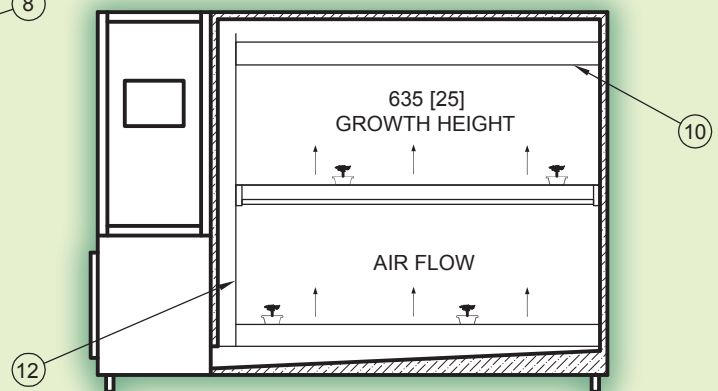

SECTIONED FRONT VIEW



SHORT PLANT SERIES
SPC-28



Biochambers SPC-28 Specifications version 2024-04A.
Our policy of continuous product improvement will occasionally result in changes to product specifications without notice.
©BIOCHAMBERS INCORPORATED 2024. ALL RIGHTS RESERVED PRINTED IN CANADA

biochambers.com